

# NB6L14

## 2.5 V/3.3 V 3.0 GHz Differential 1:4 LVPECL Fanout Buffer

### Multi-Level Inputs with Internal Termination

#### Description

The NB6L14 is a 3.0 GHz differential 1:4 LVPECL clock or data fanout buffer. The differential inputs incorporate internal 50  $\Omega$  termination resistors that are accessed through the VT pin. This feature allows the NB6L14 to accept various logic standards, such as LVPECL, LVCMOS, LVTTTL, CML, or LVDS logic levels. The VREF\_AC reference output can be used to rebias capacitor-coupled differential or single-ended input signals. The 1:4 fanout design was optimized for low output skew applications.

The NB6L14 is a member of the ECLinPS MAX™ family of high performance clock and data management products.

#### Features

- Input Clock Frequency > 3.0 GHz
- Input Data Rate > 2.5 Gb/s
- < 20 ps Within Device Output Skew
- 350 ps Typical Propagation Delay
- 150 ps Typical Rise and Fall Times
- Differential LVPECL Outputs, 700 mV Amplitude, Typical
- LVPECL Mode Operating Range:  $V_{CC} = 2.375$  V to 3.63 V with  $GND = 0$  V
- Internal 50  $\Omega$  Input Termination Resistors Provided
- VREF\_AC Reference Output Voltage
- $-40^{\circ}\text{C}$  to  $+85^{\circ}\text{C}$  Ambient Operating Temperature
- Available in 3 mm x 3 mm 16 Pin QFN
- These are Pb-Free Devices



ON Semiconductor®

<http://onsemi.com>

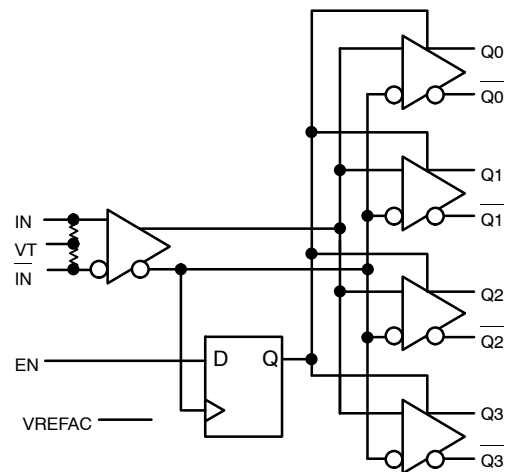
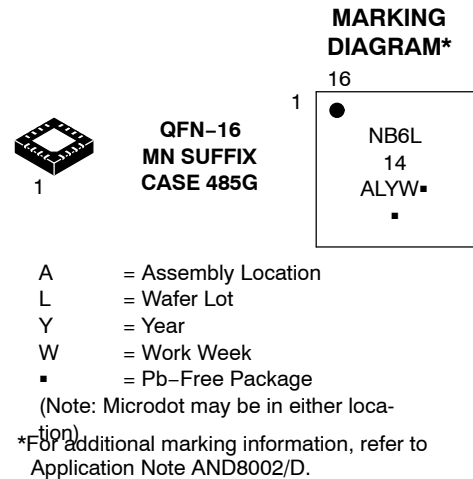
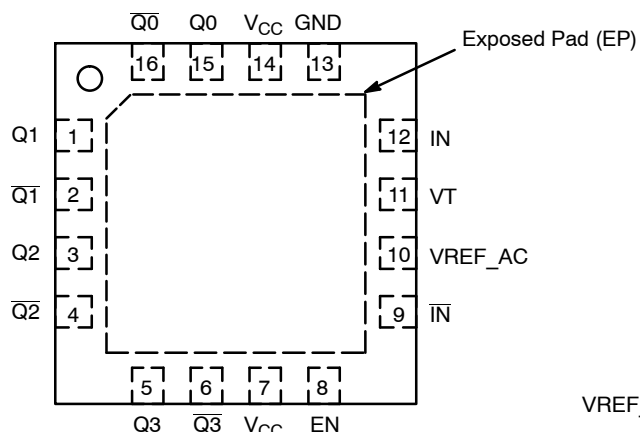


Figure 1. Simplified Logic Diagram

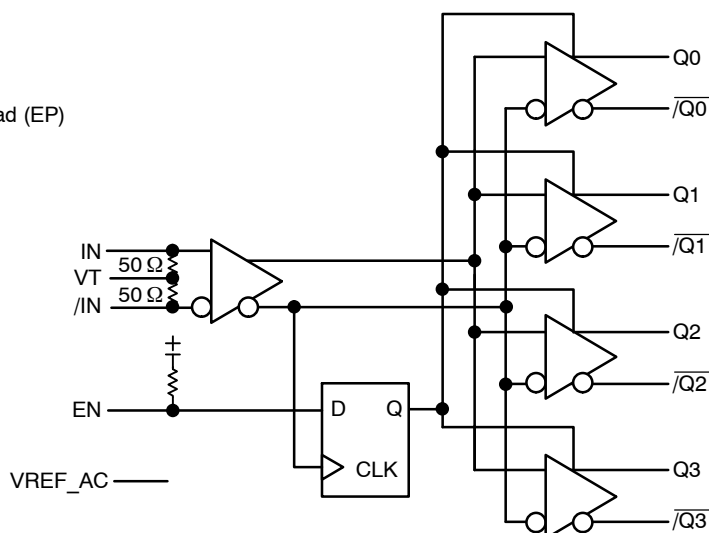
#### ORDERING INFORMATION

See detailed ordering and shipping information in the package dimensions section on page 9 of this data sheet.

# NB6L14



**Figure 2. QFN-16 Pinout**  
(Top View)



**Figure 3. Logic Diagram**

**Table 1. EN TRUTH TABLE**

IN	IN̄	EN	Q0:Q3	Q0̄:Q3̄
0	1	1	0	1
1	0	1	1	0
x	x	0	0+	1+

+ = On next negative transition of the input signal (IN).  
x = Don't care.

**Table 2. PIN DESCRIPTION**

Pin	Name	I/O	Description
1	Q1	LVPECL Output	Non-inverted Differential Output. Typically Terminated with 50 Ω Resistor to V <sub>CC</sub> -2.0 V.
2	Q1̄	LVPECL Output	Inverted Differential Output. Typically Terminated with 50 Ω Resistor to V <sub>CC</sub> -2.0 V.
3	Q2	LVPECL Output	Non-inverted Differential Output. Typically Terminated with 50 Ω Resistor to V <sub>CC</sub> -2.0 V.
4	Q2̄	LVPECL Output	Inverted Differential Output. Typically Terminated with 50 Ω Resistor to V <sub>CC</sub> -2.0 V.
5	Q3	LVPECL Output	Non-inverted Differential Output. Typically Terminated with 50 Ω Resistor to V <sub>CC</sub> -2.0 V.
6	Q3̄	LVPECL Output	Inverted Differential Output. Typically Terminated with 50 Ω Resistor to V <sub>CC</sub> -2.0 V.
7	V <sub>CC</sub>	-	Positive Supply Voltage
8	EN	LVTTTL/LVCMOS	Synchronous Output Enable. When LOW, Q outputs will go LOW and Q̄ outputs will go HIGH on the next negative transition of IN input. The internal DFF register is clocked on the falling edge of IN input (see Figure 20). The EN pin has an internal pullup resistor and defaults HIGH when left open.
9	IN̄	LVPECL, CML, LVDS, HSTL	Inverted Differential Clock Input. Internal 50 Ω Resistor to Termination Pin, VT.
10	VREF_AC		Output Voltage Reference for capacitor-coupled inputs, only.
11	VT		Internal 100 Ω center-tapped Termination Pin for IN and IN̄.
12	IN	LVPECL, CML, LVDS, HSTL	Non-inverted Differential Clock Input. Internal 50 Ω Resistor to Termination Pin, VT.
13	GND	-	Negative Supply Voltage
14	V <sub>CC</sub>	-	Positive Supply Voltage
15	Q0	LVPECL Output	Noninverted Differential Output. Typically Terminated with 50 Ω Resistor to V <sub>CC</sub> -2.0 V.
16	Q0̄	LVPECL Output	Inverted Differential Output. Typically Terminated with 50 Ω Resistor to V <sub>CC</sub> -2.0 V.
-	EP	-	The Exposed Pad (EP) on the QFN-16 package bottom is thermally connected to the die for improved heat transfer out of package. The exposed pad must be attached to a heat-sinking conduit. The pad is not electrically connected to the die, but is recommended to be electrically and thermally connected to GND on the PC board.

1. In the differential configuration when the input termination pin VT, is connected to a common termination voltage or left open, and if no signal is applied on IN/IN̄ inputs, then the device will be susceptible to self-oscillation.

# NB6L14

**Table 3. ATTRIBUTES**

Characteristics		Value
ESD Protection	Human Body Model Machine Model	> 4 kV > 100 V
Moisture Sensitivity (Note 2)	QFN-16	Level 1
Flammability Rating	Oxygen Index: 28 to 34	UL 94 V-0 @ 0.125 in
Transistor Count		167
Meets or exceeds JEDEC Spec EIA/JESD78 IC Latchup Test		

2. For additional information, see Application Note AND8003/D.

**Table 4. MAXIMUM RATINGS**

Symbol	Parameter	Condition 1	Condition 2	Rating	Unit
$V_{CC}$	Positive Power Supply	GND = 0 V		4.0	V
$V_{IO}$	Positive Input/Output	GND = 0 V	$-0.5\text{ V} \leq V_{IO} \leq V_{CC} + 0.5\text{ V}$	4.0	V
$I_{IN}$	Input Current Source or Sink Current ( $I_{IN}/\bar{I}_{IN}$ )			$\pm 50$	mA
$I_{VREF\_AC}$	Source or Sink Current on VT Pin			$\pm 2.0$	mA
$I_{OUT}$	Output Current	Continuous Surge		50 100	mA mA
$T_A$	Operating Temperature Range			-40 to +85	°C
$T_{stg}$	Storage Temperature Range			-65 to +150	°C
$\theta_{JA}$	Thermal Resistance (Junction-to-Ambient) (Note 3)	0 lfp 500 lfp	QFN-16 QFN-16	42 35	°C/W °C/W
$\theta_{JC}$	Thermal Resistance (Junction-to-Case)	(Note 3)	QFN-16	4	°C/W
$T_{sol}$	Wave Solder Pb-Free			265	°C

Stresses exceeding Maximum Ratings may damage the device. Maximum Ratings are stress ratings only. Functional operation above the Recommended Operating Conditions is not implied. Extended exposure to stresses above the Recommended Operating Conditions may affect device reliability.

3. JEDEC standard multilayer board – 2S2P (2 signal, 2 power) with 8 filled thermal vias under exposed pad.

## NB6L14

**Table 5. DC CHARACTERISTICS, Multi-Level Inputs, LVPECL Outputs**

$V_{CC} = 2.375\text{ V to }3.63\text{ V}$ ,  $GND = 0\text{ V}$ ,  $T_A = -40^\circ\text{C to }+85^\circ\text{C}$

Symbol	Characteristic	Min	Typ	Max	Unit
$I_{CC}$	Power Supply Current (Inputs and Outputs Open)	35	47	65	mA

### LVPECL OUTPUT DC ELECTRICAL CHARACTERISTICS

$V_{OH}$	Output HIGH Voltage (Notes 4 and 5) ( $Q, \bar{Q}$ ) $V_{CC} = 3.3\text{ V}$ $V_{CC} = 2.5\text{ V}$	$V_{CC} - 1145$ 2155 1355	$V_{CC} - 1020$ 2280 1480	$V_{CC} - 895$ 2405 1605	mV
$V_{OL}$	Output LOW Voltage (Notes 4 and 5) ( $Q, \bar{Q}$ ) $V_{CC} = 3.3\text{ V}$ $V_{CC} = 2.5\text{ V}$	$V_{CC} - 1945$ 1355 555	$V_{CC} - 1875$ 1475 675	$V_{CC} - 1695$ 1605 805	mV

### DIFFERENTIAL INPUT DRIVEN SINGLE-ENDED (See Figures 10 and 11)

$V_{th}$	Input Threshold Reference Voltage Range (Note 6)	1100		$V_{CC} - 100$	mV
$V_{IH}$	Single-Ended Input High Voltage	$V_{th} + 100$		$V_{CC}$	mV
$V_{IL}$	Single-Ended Input LOW Voltage	GND		$V_{th} - 100$	mV
$V_{ISE}$	Single-Ended Input Voltage Amplitude ( $V_{IH} - V_{IL}$ )	200		$V_{CC} - GND$	mV

### $V_{REFAC}$

$V_{REFAC}$	Output Reference Voltage ( $V_{CC} \geq 2.5\text{ V}$ )	$V_{CC} - 1.525$	$V_{CC} - 1.425$	$V_{CC} - 1.325$	mV
-------------	---	------------------	------------------	------------------	----

### DIFFERENTIAL INPUTS DRIVEN DIFFERENTIALLY (See Figures 12 and 13) (Note 7)

$V_{IHD}$	Differential Input HIGH Voltage	1200		$V_{CC}$	mV
$V_{ILD}$	Differential Input LOW Voltage	GND		$V_{IHD} - 100$	mV
$V_{CMR}$	Input Common Mode Range (Differential Configuration) (Note 8)	950		$V_{CC} - 50$	mV
$V_{ID}$	Differential Input Voltage ( $I_N - \bar{I}_N$ ) ( $V_{IHD} - V_{ILD}$ )	100		$V_{CC} - GND$	mV
$I_{IH}$	Input HIGH Current (VT Open) $I_N/\bar{I}_N$	-150		+150	$\mu\text{A}$
$I_{IL}$	Input LOW Current (VT Open) $I_N/\bar{I}_N$	-150		+150	$\mu\text{A}$

### LVTTTL/LVCMOS INPUT DC ELECTRICAL CHARACTERISTICS

$V_{IH}$	Input HIGH Voltage	2.0		$V_{CC}$	V
$V_{IL}$	Input LOW Voltage	GND		0.8	V
$I_{IH}$	Input HIGH Current, $V_{CC} = V_{IN} = 3.63\text{ V}$	-10		50	$\mu\text{A}$
$I_{IL}$	Input LOW Current, $V_{CC} = 3.63\text{ V}$ , $V_{IN} = 0\text{ V}$	-150		0	$\mu\text{A}$

### TERMINATION RESISTORS

$R_{TIN}$	Internal Input Termination Resistor (IN to VT)	40	50	60	$\Omega$
$R_{DIFF\_IN}$	Differential Input Resistance (IN to $\bar{I}_N$ )	80	100	120	$\Omega$

NOTE: Device will meet the specifications after thermal equilibrium has been established when mounted in a test socket or printed circuit board with maintained transverse airflow greater than 500 lfm. Electrical parameters are guaranteed only over the declared operating temperature range. Functional operation of the device exceeding these conditions is not implied. Device specification limit values are applied individually under normal operating conditions and not valid simultaneously.

4. LVPECL outputs loaded with  $50\ \Omega$  to  $V_{CC} - 2.0\text{ V}$  for proper operation.
5. Input and output parameters vary 1:1 with  $V_{CC}$ .
6.  $V_{th}$  is applied to the complementary input when operating in single-ended mode.
7.  $V_{IHD}$ ,  $V_{ILD}$ ,  $V_{ID}$  and  $V_{CMR}$  parameters must be complied with simultaneously.
8.  $V_{CMR}$  min varies 1:1 with GND,  $V_{CMR}$  max varies 1:1 with  $V_{CC}$ . The  $V_{CMR}$  range is referenced to the most positive side of the differential input signal.

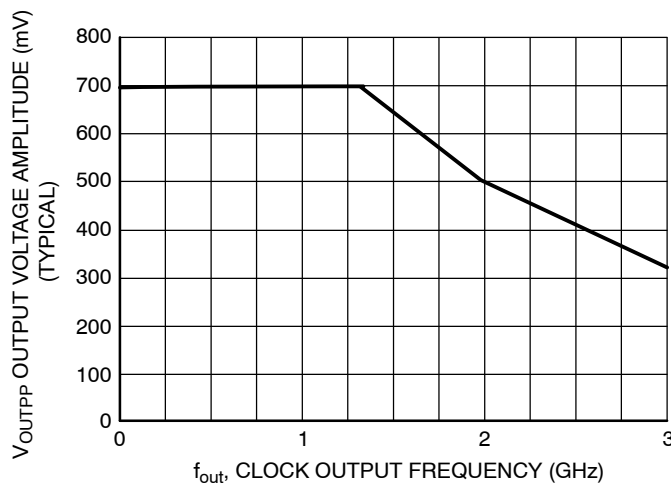
# NB6L14

**Table 6. AC CHARACTERISTICS**  $V_{CC} = 2.375\text{ V to }3.63\text{ V}$ ,  $GND = 0\text{ V}$ ,  $T_A = -40^\circ\text{C to }+85^\circ\text{C}$  (Note 9)

Symbol	Characteristic	Min	Typ	Max	Unit
$V_{OUTPP}$	Output Voltage Amplitude (@ $V_{INPPmin}$ ) (Note 10) $f_{IN} \leq 1.25\text{ GHz}$ $1.25\text{ GHz} \leq f_{IN} \leq 2.0\text{ GHz}$ $2.0\text{ GHz} \leq f_{IN} \leq 3.0\text{ GHz}$	550 380 250	700 500 320		mV
$f_{DATA}$	Maximum Operating Data Rate		2.5		Gb/s
$t_{PD}$	Propagation Delay IN to Q	250	370	500	ps
$t_S$	Set-Up Time (Note 11) EN to IN, $\overline{IN}$	300			ps
$t_H$	Hold Time (Note 11) EN to IN, $\overline{IN}$	300			ps
$t_{SKEW}$	Within-Device Skew (Note 12) Device to Device Skew (Note 13)		5.0	20 150	ps
$t_{JITTER}$	RMS Random Jitter (Note 14) Peak-to-Peak Data Dependent Jitter (Note 15) $f_{IN} = 2.5\text{ GHz}$ $f_{DATA} = 2.5\text{ Gb/s}$		14	1.0	ps
$V_{INPP}$	Input Voltage Swing/Sensitivity (Differential Configuration) (Note 10)	100		$V_{CC} - GND$	mV
$t_r, t_f$	Output Rise/Fall Times @ Full Output Swing (20%–80%)	70	150	200	ps

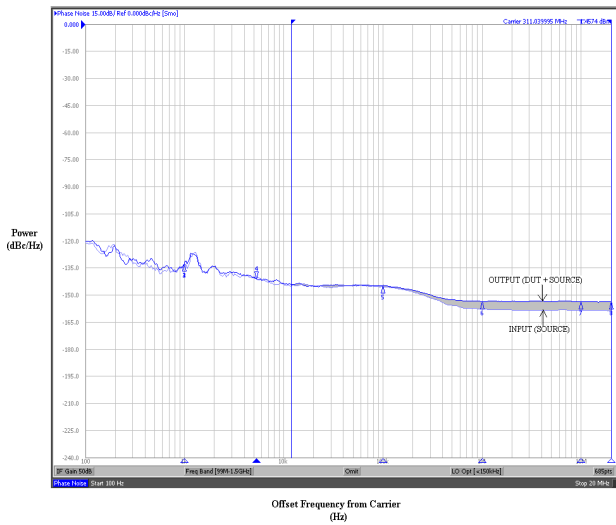
NOTE: Device will meet the specifications after thermal equilibrium has been established when mounted in a test socket or printed circuit board with maintained transverse airflow greater than 500 lfpm. Electrical parameters are guaranteed only over the declared operating temperature range. Functional operation of the device exceeding these conditions is not implied. Device specification limit values are applied individually under normal operating conditions and not valid simultaneously.

9. Measured by forcing  $V_{INPP}$  (min) from a 50% duty cycle clock source. All loading with an external  $R_L = 50\ \Omega$  to  $V_{CC} - 2.0\text{ V}$ . Input edge rates 40 ps (20%–80%).
10. Input and output voltage swing is a single-ended measurement operating in differential mode.
11. Set-up and hold times apply to synchronous applications that intend to enable/disable before the next clock cycle. For asynchronous applications, set-up and hold times do not apply.
12. Within device skew is measured between two different outputs under identical power supply, temperature and input conditions.
13. Device to device skew is measured between outputs under identical transition @ 0.5 GHz.
14. Additive RMS jitter with 50% duty cycle clock signal.
15. Additive peak-to-peak data dependent jitter with input NRZ data at PRBS  $2^{23}-1$  and K28.5 at 2.5Gb/s.

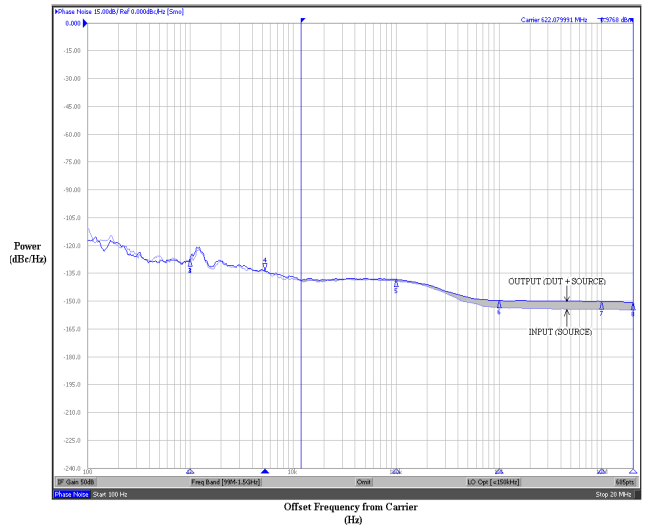


**Figure 4. Output Voltage Amplitude ( $V_{OUTPP}$ ) versus Output Frequency at Ambient Temperature (Typical)**

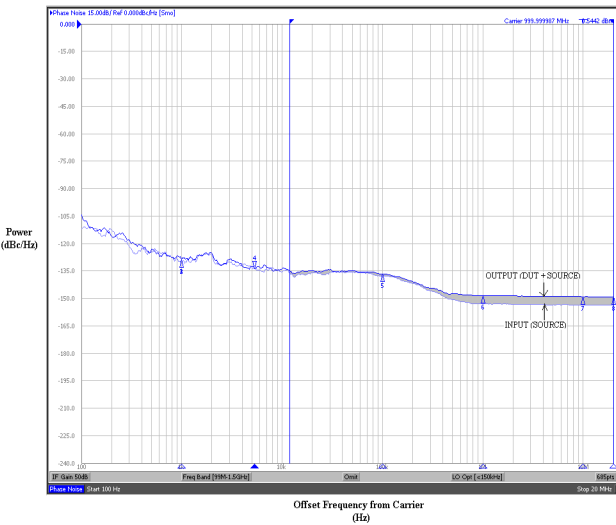
# NB6L14



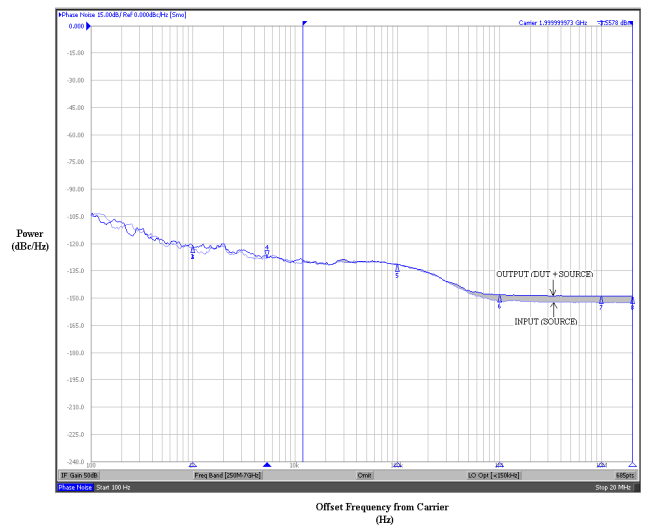
**Figure 5. Typical Phase Noise Plot at  $f_{\text{carrier}} = 311.04 \text{ MHz}$**



**Figure 6. Typical Phase Noise Plot at  $f_{\text{carrier}} = 622.08 \text{ MHz}$**



**Figure 7. Typical Phase Noise Plot at  $f_{\text{carrier}} = 1 \text{ GHz}$**



**Figure 8. Typical Phase Noise Plot at  $f_{\text{carrier}} = 2 \text{ GHz}$**

The above phase noise plots captured using Agilent E5052A show additive phase noise of the NB6L14 device at frequencies 311.04 MHz, 622.08 MHz, 1 GHz and 2 GHz respectively at an operating voltage of 3.3 V in room temperature. The RMS Phase Jitter contributed by the

device (integrated between 12 kHz and 20 MHz; as shown in the shaded region of the plot) at each of the frequencies is 27 fs, 17 fs, 13 fs and 5 fs respectively. The input source used for the phase noise measurements is Agilent E8663B.

# NB6L14

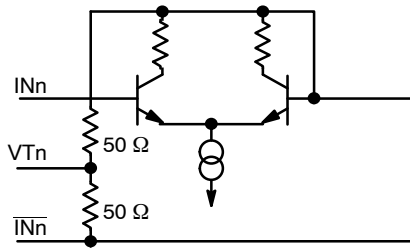


Figure 9. Input Structure

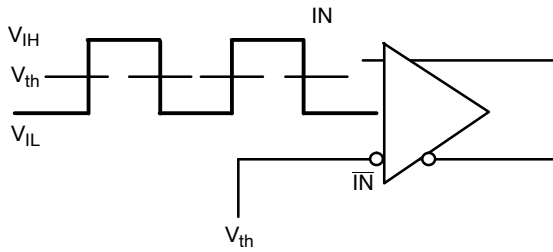


Figure 10. Differential Input Driven Single-Ended

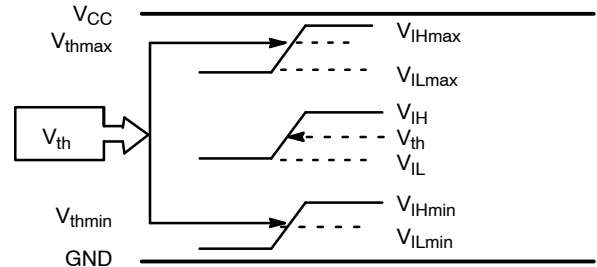


Figure 11.  $V_{th}$  Diagram

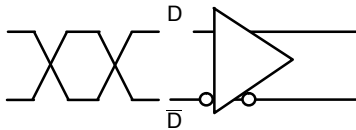


Figure 12. Differential Inputs Driven Differentially

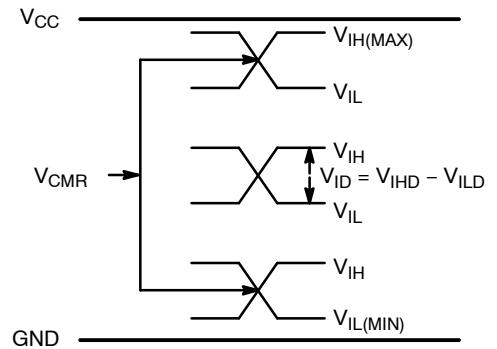


Figure 13.  $V_{CMR}$  Diagram

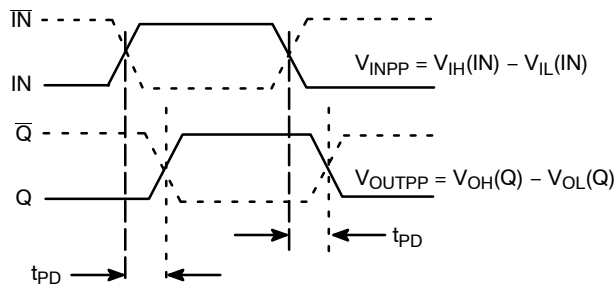


Figure 14. AC Reference Measurement

# NB6L14

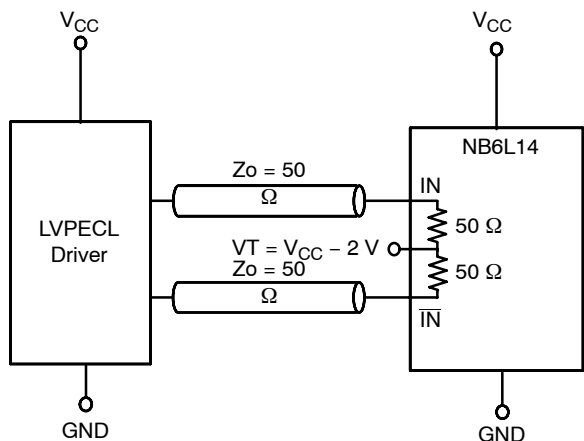


Figure 15. LVPECL Interface

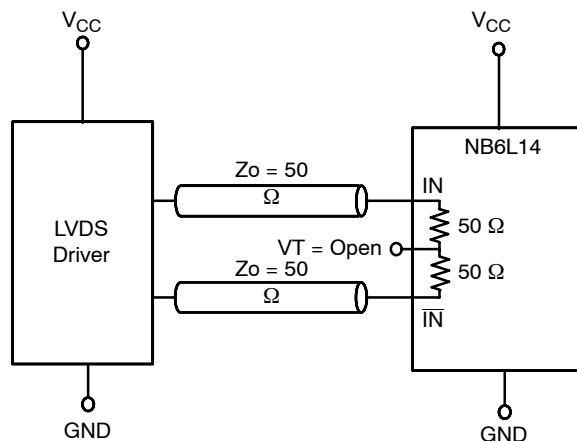


Figure 16. LVDS Interface

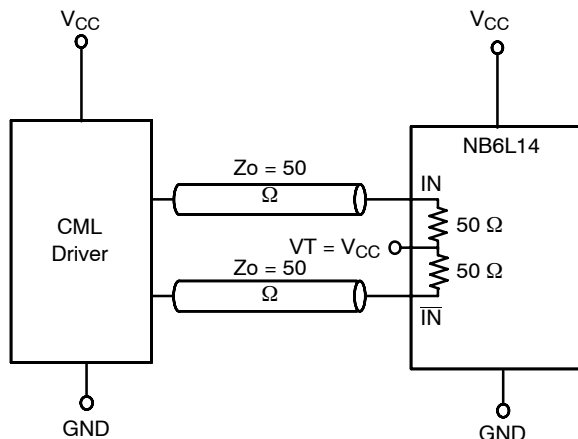


Figure 17. Standard 50  $\Omega$  Load CML Interface

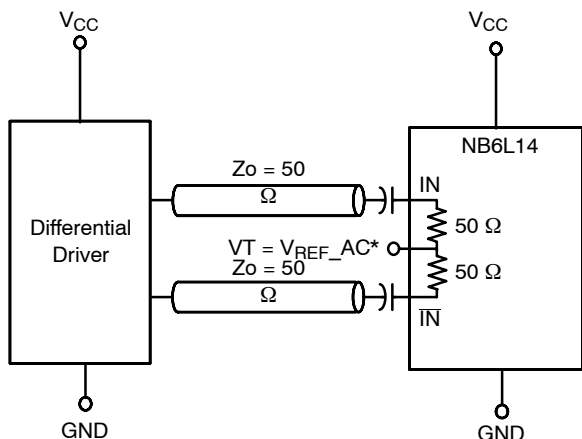


Figure 18. Capacitor-Coupled Differential Interface  
(VT Connected to V<sub>REFAC</sub>)

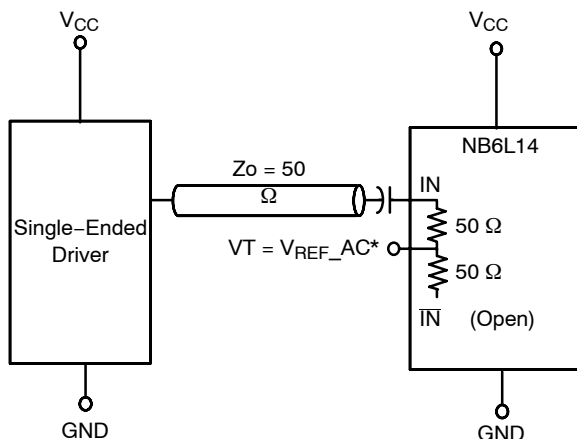


Figure 19. Capacitor-Coupled Single-Ended Interface  
(VT Connected to V<sub>REFAC</sub>)

\*V<sub>REFAC</sub> bypassed to ground with a 0.01  $\mu$ F capacitor



# NB6L14

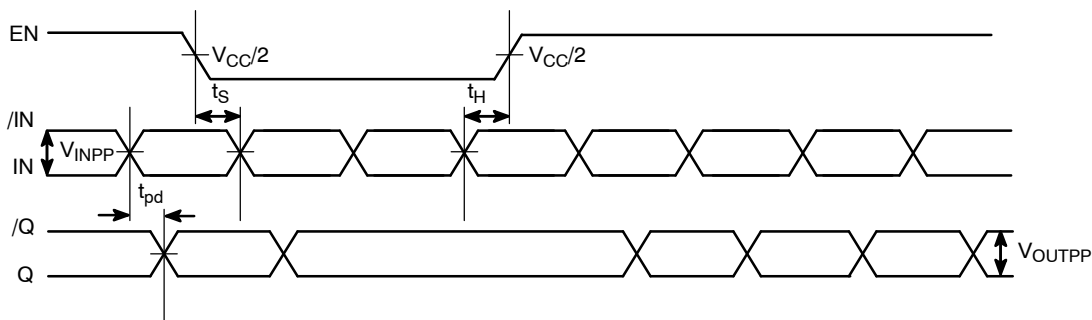


Figure 20. EN Timing Diagram

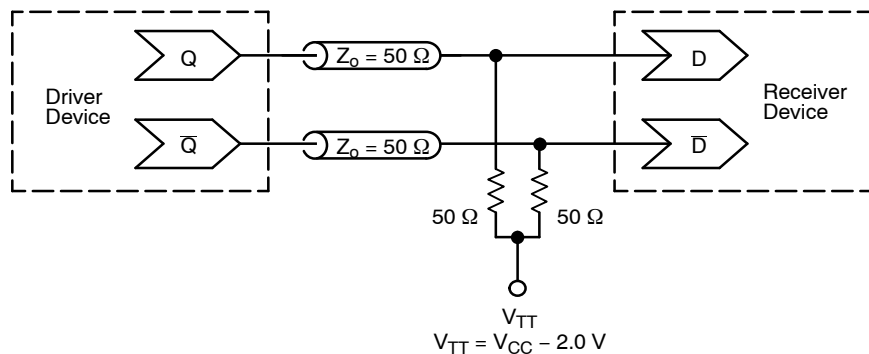


Figure 21. Typical Termination for Output Driver and Device Evaluation (See Application Note AND8020/D – Termination of ECL Logic Devices.)

## ORDERING INFORMATION

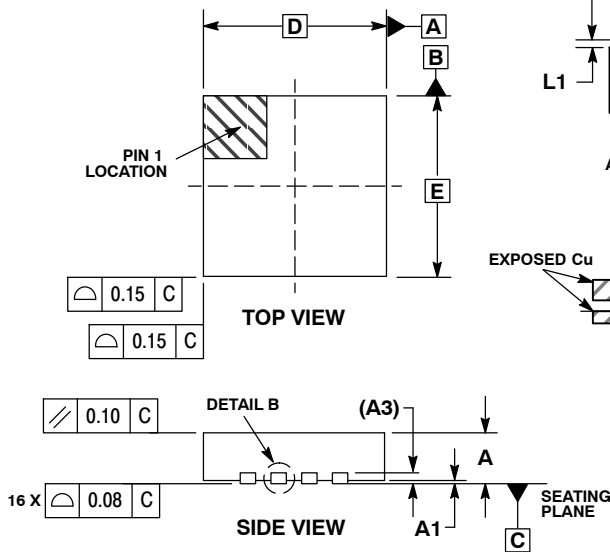
Device	Package	Shipping <sup>†</sup>
NB6L14MNG	QFN-16, 3x3 mm (Pb-Free)	123 Units / Rail
NB6L14MNR2G	QFN-16, 3x3 mm (Pb-Free)	3000 / Tape & Reel

<sup>†</sup>For information on tape and reel specifications, including part orientation and tape sizes, please refer to our Tape and Reel Packaging Specifications Brochure, BRD8011/D.

# NB6L14

## PACKAGE DIMENSIONS

### 16 PIN QFN CASE 485G-01 ISSUE D

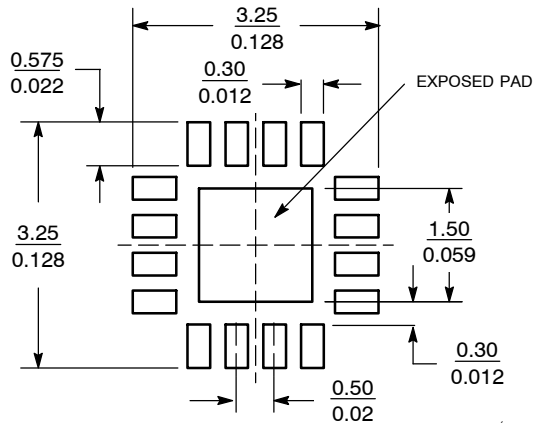
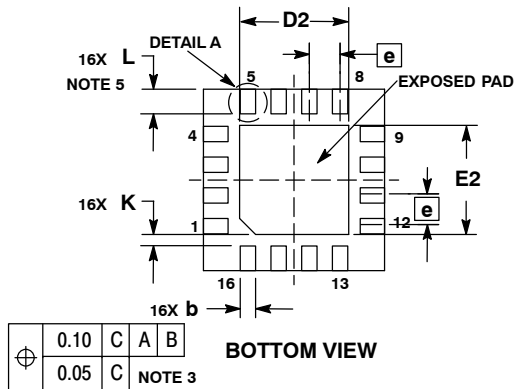


**NOTES:**

1. DIMENSIONING AND TOLERANCING PER ASME Y14.5M, 1994.
2. CONTROLLING DIMENSION: MILLIMETERS.
3. DIMENSION b APPLIES TO PLATED TERMINAL AND IS MEASURED BETWEEN 0.25 AND 0.30 MM FROM TERMINAL.
4. COPLANARITY APPLIES TO THE EXPOSED PAD AS WELL AS THE TERMINALS.
5. L<sub>max</sub> CONDITION CAN NOT VIOLATE 0.2 MM MINIMUM SPACING BETWEEN LEAD TIP AND FLAG

MILLIMETERS		
DIM	MIN	MAX
A	0.80	1.00
A1	0.00	0.05
A3	0.20 REF	
b	0.18	0.30
D	3.00 BSC	
D2	1.65	1.85
E	3.00 BSC	
e	0.50 BSC	
K	0.18 TYP	
L	0.30	0.50
L1	0.00	0.15

### SOLDERING FOOTPRINT\*



SCALE 10:1 (mm/inches)

\*For additional information on our Pb-Free strategy and soldering details, please download the ON Semiconductor Soldering and Mounting Techniques Reference Manual, SOLDERM/D.

ECLinPS MAX is a trademark of Semiconductor Components Industries, LLC (SCILLC).

ON Semiconductor and are registered trademarks of Semiconductor Components Industries, LLC (SCILLC). SCILLC reserves the right to make changes without further notice to any products herein. SCILLC makes no warranty, representation or guarantee regarding the suitability of its products for any particular purpose, nor does SCILLC assume any liability arising out of the application or use of any product or circuit, and specifically disclaims any and all liability, including without limitation special, consequential or incidental damages. "Typical" parameters which may be provided in SCILLC data sheets and/or specifications can and do vary in different applications and actual performance may vary over time. All operating parameters, including "Typicals" must be validated for each customer application by customer's technical experts. SCILLC does not convey any license under its patent rights nor the rights of others. SCILLC products are not designed, intended, or authorized for use as components in systems intended for surgical implant into the body, or other applications intended to support or sustain life, or for any other application in which the failure of the SCILLC product could create a situation where personal injury or death may occur. Should Buyer purchase or use SCILLC products for any such unintended or unauthorized application, Buyer shall indemnify and hold SCILLC and its officers, employees, subsidiaries, affiliates, and distributors harmless against all claims, costs, damages, and expenses, and reasonable attorney fees arising out of, directly or indirectly, any claim of personal injury or death associated with such unintended or unauthorized use, even if such claim alleges that SCILLC was negligent regarding the design or manufacture of the part. SCILLC is an Equal Opportunity/Affirmative Action Employer. This literature is subject to all applicable copyright laws and is not for resale in any manner.

### PUBLICATION ORDERING INFORMATION

**LITERATURE FULFILLMENT:**  
Literature Distribution Center for ON Semiconductor  
P.O. Box 5163, Denver, Colorado 80217 USA  
**Phone:** 303-675-2175 or 800-344-3860 Toll Free USA/Canada  
**Fax:** 303-675-2176 or 800-344-3867 Toll Free USA/Canada  
**Email:** orderlit@onsemi.com

**N. American Technical Support:** 800-282-9855 Toll Free USA/Canada  
**Japan:** ON Semiconductor, Japan Customer Focus Center  
2-9-1 Kamimeguro, Meguro-ku, Tokyo, Japan 153-0051  
**Phone:** 81-3-5773-3850

**ON Semiconductor Website:** <http://onsemi.com>  
**Order Literature:** <http://www.onsemi.com/litorder>

For additional information, please contact your local Sales Representative.